

NLP Tasks and Applications

600.465 - Intro to NLP - J. Eisner

1

The NLP Research Community

- **Papers**
 - **ACL Anthology** has nearly everything, free!
 - Over 20,000 papers!
 - Free-text searchable
 - Great way to learn about current research on a topic
 - New search interfaces currently available in beta
 - Find recent or highly cited work; follow citations
 - Used as a dataset by various projects
 - Analyzing the text of the papers (e.g., parsing it)
 - Extracting a graph of papers, authors, and institutions (Who wrote what? Who works where? What cites what?)

The NLP Research Community

- **Conferences**
 - Most work in NLP is published as 8-page conference papers with 3 double-blind reviewers.
 - Main annual conferences: ACL, EMNLP, NAACL
 - Also EACL, IJCNLP, COLING
 - + various specialized conferences and workshops
 - Big events, and growing fast! **ACL 2011**:
 - About 1000 attendees
 - 634 full-length papers submitted (164 accepted)
 - 512 short papers submitted (128 accepted)
 - 16 **workshops** on various topics

The NLP Research Community

- **Institutions**
 - **Universities**: Many have 2+ NLP faculty
 - Several "big players" with many faculty
 - Some of them also have good linguistics, cognitive science, machine learning, AI
 - **Companies**:
 - Old days: AT&T Bell Labs, IBM
 - Now: Google, Microsoft, IBM, many startups ...
 - Speech: Nuance, ...
 - Machine translation: Language Weaver, Systran, ...
 - Many niche markets – online reviews, medical transcription, news summarization ...

The NLP Research Community

- **Standard tasks**
 - If you want people to work on your problem, make it easy for them to get started and to measure their progress. Provide:
 - **Test data**, for evaluating the final systems
 - **Development data**, for measuring whether a change to the system helps, and for tuning parameters
 - An **evaluation metric** (formula for measuring how well a system does on the dev or test data)
 - A **program** for computing the evaluation metric
 - **Labeled training data** and other data resources
 - A **prize?** – with clear **rules** on what data can be used

The NLP Research Community

- **Software**
 - Lots of people distribute code for these tasks
 - Or you can email a paper's authors to ask for their code
 - Some **lists** of software, but no central site ☺
 - Some **end-to-end pipelines** for text analysis
 - "One-stop shopping"
 - Cleanup/tokenization + morphology + tagging + parsing + ...
 - **NLTK** is easy for beginners and has a **free book** (intersession?)
 - **GATE** has been around for a long time and has a bunch of modules

The NLP Research Community

- **Software**
 - To find good or popular tools:
 - Search current papers, ask around, use the web
 - Still, often hard to identify the **best** tool for your job:
 - Produces appropriate, sufficiently detailed output?
 - Accurate? (on the measure you care about)
 - Robust? (accurate on your data, not just theirs)
 - Fast?
 - Easy and flexible to use? Nice file formats, command line options, visualization?
 - Trainable for new data and languages? How slow is training?
 - Open-source and easy to extend?

The NLP Research Community

- **Datasets**
 - Raw text or speech corpora
 - Or just their *n-gram counts*, for super-big corpora
 - Various languages and genres
 - Usually there's some metadata (each document's date, author, etc.)
 - Sometimes \exists licensing restrictions (proprietary or copyright data)
 - Text or speech with manual or automatic annotations
 - What kind of annotations? That's the rest of this lecture ...
 - May include translations into other languages
 - Words and their relationships
 - *Morphological, semantic*, translational, evolutionary
 - *Grammars*
 - *World Atlas of Linguistic Structures*
 - Parameters of statistical models (e.g., grammar weights)

The NLP Research Community

- **Datasets**
 - Read papers to find out what datasets others are using
 - *Linguistic Data Consortium* (searchable) hosts many large datasets
 - Many projects and competitions post data on their websites
 - But sometimes you have to email the author for a copy
 - *CORPORA mailing list* is also good place to ask around
 - *LREC Conference* publishes papers about new datasets & metrics
 - *Amazon Mechanical Turk* – pay humans (very cheaply) to annotate your data or to correct automatic annotations
 - *Old task, new domain*: Annotate parses etc. on *your* kind of data
 - *New task*: Annotate something new that you want your system to find
 - *Auxiliary task*: Annotate something new that your system may benefit from finding (e.g., annotate subjunctive mood to improve translation)
 - Can you make annotation so much *fun* or so *worthwhile* that they'll do it for free?

The NLP Research Community

- **Standard data formats**
 - Often just simple *ad hoc* text-file formats
 - Documented in a README; easily read with scripts
 - Some standards:
 - *Unicode* – strings in any language (see *ICU* toolkit)
 - *PCM* (.wav, .aiff) – uncompressed audio
 - *BWF* and *AUP* extend w/metadata; also many compressed formats
 - *XML* – documents with embedded annotations
 - *Text Encoding Initiative* – faithful digital representations of printed text
 - *Protocol Buffers, JSON* – structured data
 - *UIMA* – “unstructured information management”; Watson uses it
 - Standoff markup: raw text in one file, annotations in other files (“ \exists noun phrase from byte 378–392”)
 - Annotations can be independently contributed & distributed

Text Annotation Tasks

1. Classify the entire document (“text categorization”)

Sentiment classification



What features of the text could help predict # of stars? (e.g., using a log-linear model) How to identify more? Are the features hard to compute? (syntax? sarcasm?)

★☆☆☆ An extremely versatile machine!, November 22, 2006

By [Dr. Nicolas E. Jorgensen "njorgens3"](#)

This review is from: *Cuisinart DGB-600BC Grind & Brew, Brushed Chrome (Kitchen)*

This coffee-maker does so much! It makes weak, watery coffee! It grinds beans if you want it to! It inexplicably floods the entire counter with half-brewed coffee when you aren't looking! Perhaps it could be used to irrigate crops... It is time-consuming to clean, but in fairness I should also point out that the stainless-steel thermal carafe is a durable item that has withstood being hurled onto the floor in rage several times. And if all these features weren't enough, it's pretty expensive too. If faced with the choice between having a car door repeatedly slamming into my genitalia and buying this coffee-maker, I'd unhesitatingly choose the Cuisinart! The coffee would be lousy, but at least I could still have children...

Other text categorization tasks

- Is it **spam**? (see **features**)
- What **medical billing code** for this visit?
- What **grade**, as an answer to this essay question?
- Is it **interesting to this user**?
 - News filtering; helpdesk routing
- Is it **interesting to this NLP program**?
 - If it's **Spanish**, translate it from Spanish
 - If it's **subjective**, run the sentiment classifier
 - If it's an **appointment**, run information extraction
- Where should it be **filed**?
 - Which mail folder? (work, friends, junk, urgent ...)
 - Yahoo! / Open Directory / digital libraries

600.465 - Intro to NLP - J. Eisner

13

Measuring Performance

- Classification accuracy**: What % of messages were classified correctly?
- Is this what we care about?**

	Overall accuracy	Accuracy on spam	Accuracy on gen
System 1	95%	99.99%	90%
System 2	95%	90%	99.99%

- Which system do you prefer?

600.465 - Intro to NLP - J. Eisner

14

Measuring Performance

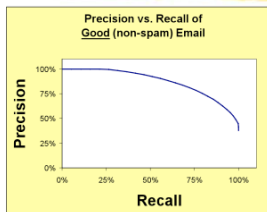

Move from high precision to high recall by deleting fewer messages (delete only if spamminess > high threshold)

600.465 - Intro to NLP - J. Eisner

15

- Precision** = good messages kept / all messages kept
- Recall** = good messages kept / all good messages

Measuring Performance

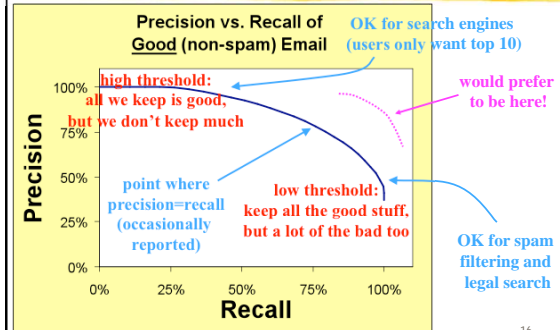

16

Measuring Performance

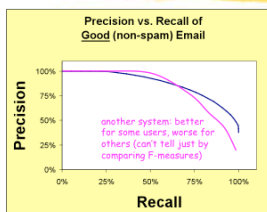

Move from high precision to high recall by deleting fewer messages (raise threshold)
Conventional to tune system and threshold to optimize F-measure on dev data
But it's more informative to report the whole curve
Since in real life, the user should be able to pick a tradeoff point they like

600.465 - Intro to NLP - J. Eisner

17

- Precision** = good messages kept / all messages kept
- Recall** = good messages kept / all good messages
- F-measure** = $\left(\frac{\text{precision}^{-1} + \text{recall}^{-1}}{2} \right)^{-1}$

Supervised Learning Methods

- Conditional log-linear models are a good hammer**
 - Feature engineering: Throw in enough features to fix most errors
 - Training**: Learn weights θ such that in training data, the true answer tends to have a **high probability**
 - Test**: Output the highest-probability answer

If the evaluation metric allows for partial credit, can do fancier things ("minimum-risk" training and decoding)

- The most popular alternatives are roughly similar**
 - Perceptron, SVM, MIRA, neural network, ...
 - These also learn a (usually linear) scoring function
 - However, the score is not interpreted as a log-probability
 - Learner just seeks weights θ such that in training data, the desired answer has a **higher score** than the wrong answers

Fancier Performance Metrics

- For multi-way classifiers:
 - Average accuracy (or precision or recall) of 2-way distinctions: Sports or not, News or not, etc.
 - Better, estimate the cost of different *kinds* of errors
 - e.g., how bad is each of the following?
 - putting Sports articles in the News section
 - putting Fashion articles in the News section
 - putting News articles in the Fashion section
 - Now tune system to minimize total cost
- For ranking systems: Which articles are *most* Sports-like? Which articles / webpages *most* relevant?
 - Correlate with human rankings?
 - Get active feedback from user?
 - Measure user's wasted time by tracking clicks?

600.465 - Intro to NLP - J. Eisner

19

Supervised Learning Methods

- Easy to build a "yes" or "no" predictor from supervised training data
 - Plenty of software packages to do the learning & prediction
 - Lots of people in NLP never go beyond this ☺
- Similarly, easy to build a system that chooses from a small finite set
 - Basically the same deal
 - But runtime goes up linearly with the size of the set, unless you're clever (HW3)

Text Annotation Tasks

- Classify the entire document
- Classify individual word tokens

600.465 - Intro to NLP - J. Eisner

21

$p(\text{class} \mid \text{token in context})$

Word Sense Disambiguation (WSD)

Problem:

The company said the *plant* is still operating ...
 ⇒ (A) Manufacturing plant or
 ⇒ (B) Living plant

Training Data: Build a special classifier just for tokens of "plant"

Sense	Context
(1) Manufacturing	... union responses to <i>plant</i> closures
" "	... computer disk drive <i>plant</i> located in ...
" "	company manufacturing <i>plant</i> is in Orlando ...
(2) Living	... animal rather than <i>plant</i> tissues can be ...
" "	... to strain microscopic <i>plant</i> life from the ...
" "	and Golgi apparatus of <i>plant</i> and animal cells

Test Data:

Sense	Context
???	... vinyl chloride monomer <i>plant</i> , which is ...
???	... molecules found in <i>plant</i> tissue from the ...

slide courtesy of D. Yarowsky

$p(\text{class} \mid \text{token in context})$

WSD for Machine Translation (English → Spanish)

Problem:

... He wrote the last *sentence* two years later ...
 ⇒ *sentencia* (legal sentence) or
 ⇒ *frase* (grammatical sentence)

Training Data: Build a special classifier just for tokens of "sentence"

Translation	Context
(1) <i>sentencia</i>	... for a maximum <i>sentence</i> for a young offender ...
" "	... of the minimum <i>sentence</i> of seven years in jail ...
" "	... were under the <i>sentence</i> of death at that time ...
(2) <i>frase</i>	... read the second <i>sentence</i> because it is just as ...
" "	... The next <i>sentence</i> is a very important ...
" "	... It is the second <i>sentence</i> which I think is at ...

Test Data:

Translation	Context
???	... cannot criticize a <i>sentence</i> handed down by ...
???	... listen to this <i>sentence</i> uttered by a former ...

slide courtesy of D. Yarowsky

$p(\text{class} \mid \text{token in context})$

Accent Restoration in Spanish & French

Problem:

Input: ... deja travaille cote a cote ...
 ↓
 Output: ... déjà travaillé côte à côte ...

Examples:

... appeler l'autre *cote* de l'atlantique ...
 ⇒ *côté* (meaning side) or
 ⇒ *côte* (meaning coast)
 ... une famille des *pecheurs* ...
 ⇒ *pêcheurs* (meaning fishermen) or
 ⇒ *pécheurs* (meaning sinners)

slide courtesy of D. Yarowsky

p(class | token in context)

Accent Restoration in Spanish & French

Training Data:

Pattern	Context
(1) côté	... du laisser de <i>cote</i> faute de temps ...
" "	... appeler l' autre <i>cote</i> de l' atlantique ...
" "	... passe de notre <i>cote</i> de la frontiere ...
(2) côte	... vivre sur notre <i>cote</i> ouest toujours ...
" "	... creer sur la <i>cote</i> du labrador des ...
" "	travaillaient <i>cote</i> a <i>cote</i> , ils avaient ...

Test Data:

Pattern	Context
???	... passe de notre <i>cote</i> de la frontiere ...
???	... creer sur la <i>cote</i> du labrador des ...

slide courtesy of D. Yarowsky

p(class | token in context)

Capitalization Restoration

Problem:

... FRIED CHICKEN, TURKEY SANDWICHES AND FROZEN ...
 => *turkey* (the bird) or
 => *Turkey* (the country)

Training Data:

Capitalization	Context
(1) turkey	... OF FRIED CHICKEN , TURKEY SANDWICHES AND FROZEN ...
" "	... NTS A POUND , WHILE TURKEY PRICES ROSE 1,2 CENTS ...
" "	... PLAY , REAL GRADE-A TURKEY , WHICH ONLY A PRICE ...
(2) Turkey	... INUNDATED EASTERN TURKEY AFTER THE EARLIER ...
" "	... FEELINGS TOWARD TURKEY SURFACED WHEN GREECE ...
" "	... THE CONTRACT WITH TURKEY WILL PROVIDE OPPORTU...

Test Data:

Capitalization	Context
???	... NECK LIKE THAT OF A TURKEY ON A CHOPPING BLOCK ...
???	... PROBLEM IS THAT TURKEY IS NOT A EUROPEAN ...

slide courtesy of D. Yarowsky

p(class | token in context)

Text-to-Speech Synthesis

Problem:

... slightly elevated *lead* levels ...
 => *led* (as in *lead mine*) or
 => *li:d* (as in *lead role*)

Training Data:

Pronunciation	Context
(1) led	... it monitors the <i>lead</i> levels in drinking ...
" "	... conference on <i>lead</i> poisoning in ...
" "	... strontium and <i>lead</i> isotope zonation ...
(2) li:d	... maintained their <i>lead</i> Thursday over ...
" "	... to Boston and <i>lead</i> singer for Purple ...
" "	... Bush a 17-point <i>lead</i> in Texas , only 3 ...

Test Data:

Pronunciation	Context
???	... median blood <i>lead</i> concentration was ...
???	... his double-digit <i>lead</i> nationwide . The ...

slide courtesy of D. Yarowsky

p(class | token in context)

Spelling Correction

Problem:

... and he fired presidential *aid/aide* Dick Morris after ...
 => *aid* or
 => *aide*

Training Data:

Spelling	Context
(1) aid	... and cut the foreign <i>aid/aide</i> budget in fiscal 1996 ...
" "	... they offered federal <i>aid/aide</i> for flood-ravaged states ...
(2) aide	... fired presidential <i>aid/aide</i> Dick Morris after ...
" "	... and said the chief <i>aid/aide</i> to Sen. Baker, Mr. John ...

Test Data:

Spelling	Context
???	... said the longtime <i>aid/aide</i> to the Mayor of St. ...
???	... will squander the <i>aid/aide</i> it receives from the ...

slide courtesy of D. Yarowsky

slide courtesy of D. Yarowsky (modified)

What features? Example: "word to left"

Word to left	Frequency as	
	Aid	Aide
foreign	718	1
federal	297	0
western	146	0
provide	88	0
covert	26	0
oppose	13	0
future	9	0
similar	6	0
presidential	0	63
chief	0	40
longtime	0	26
aids-infected	0	2
sleepy	0	1
disaffected	0	1
indispensable	2	1
practical	2	0
squander	1	0

Spelling correction using an n-gram language model ($n \geq 2$) would use words to left and right to help predict the true word.

Similarly, an HMM would predict a word's class using classes to left and right.

But we'd like to throw in all kinds of other features, too ...

600

slide courtesy of D. Yarowsky (modified)

An assortment of possible cues ...

N-grams	Position	Collocation	led	li:d
	+1 L	lead level/N	219	0
	-1 W	narrow lead	0	70
(word, lemma, part-of-speech)	+1 w	lead in	207	898
	-1w,+1w	of lead in	162	0
	-1w,+1w	the lead in	0	301
	+1P,+2P	lead , <NOUN>	234	7
Wide-context collocations	$\pm k$ w	zinc (in $\pm k$ words)	235	0
	$\pm k$ w	copper (in $\pm k$ words)	130	0
Verb-object relationships	-V L	follow/V + lead	0	527
	-V L	take/V + lead	1	665

generates a whole bunch of potential cues – use data to find out which ones work best

Word to left	Frequency as Aid	Frequency as Aide
foreign	718	1
federal	297	0
western	146	0
provide	88	0

600.465 - Intro to NLP - J. Eisner

An assortment of possible cues ...

N-grams	Position	Collocation	led	lid
	+1L	lead level/N	219	0
	-1 w	narrow lead	0	70
(word, lemma, part-of-speech)	+1 w	lead in	207	898
	-1w,+1W	of lead in	162	0
	-1w,+1w	the lead in	0	301
	+1P,+2P	lead, <NOUN>	234	7
Wide-context collocations	±k w	zinc (in ±k words)	235	0
	±k w	copper (in ±k words)	130	0
Verb-object relationships	-V L	follow/V + lead	0	527
	-V L	take/V + lead	1	665

This feature is relatively weak, but weak features are still useful, especially since very few features will fire in a given context.

merged ranking of all cues of all these types

11.40	follow/V + lead	⇒ lid
11.20	zinc (in ±k words)	⇒ led
11.10	lead level/N	⇒ led
10.66	of lead in	⇒ led
10.59	the lead in	⇒ lid
10.51	lead role	⇒ lid

Final decision list for *lead* (abbreviated)

List of all features, ranked by their weight.

(These weights are for a simple "decision list" model where the single highest-weighted feature that fires gets to make the decision all by itself.)

However, a log-linear model, which adds up the weights of all features that fire, would be roughly similar.)

LogL	Evidence	Pronunciation
11.40	follow/V + lead	⇒ lid
11.20	zinc (in ±k words)	⇒ led
11.10	lead level/N	⇒ led
10.66	of lead in	⇒ led
10.59	the lead in	⇒ lid
10.51	lead role	⇒ lid
10.35	copper (in ±k words)	⇒ led
10.28	lead time	⇒ lid
10.24	lead levels	⇒ led
10.16	lead poisoning	⇒ led
8.55	big lead	⇒ lid
8.49	narrow lead	⇒ lid
7.76	take/V + lead	⇒ lid
5.99	lead, NOUN	⇒ led
1.15	lead in	⇒ lid
	○○○	

Part of Speech Tagging

- We could treat tagging as a token classification problem
 - Tag each word independently given features of context
 - And features of the word's spelling (suffixes, capitalization)

Sequence Labeling as Classification

- Classify each token independently but use as input features, information about the surrounding tokens (sliding window).

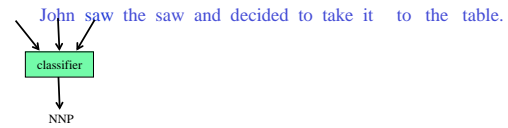

Sequence Labeling as Classification

- Classify each token independently but use as input features, information about the surrounding tokens (sliding window).

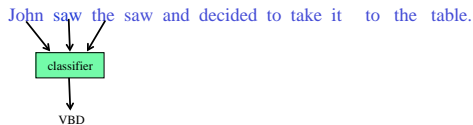

Sequence Labeling as Classification

- Classify each token independently but use as input features, information about the surrounding tokens (sliding window).

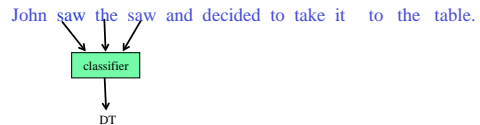

Sequence Labeling as Classification

- Classify each token independently but use as input features, information about the surrounding tokens (sliding window).

John saw the saw and decided to take it to the table.

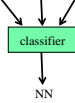

Slide from Ray Mooney

Sequence Labeling as Classification

- Classify each token independently but use as input features, information about the surrounding tokens (sliding window).

John saw the saw and decided to take it to the table.

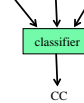

Slide from Ray Mooney

Sequence Labeling as Classification

- Classify each token independently but use as input features, information about the surrounding tokens (sliding window).

John saw the saw and decided to take it to the table.

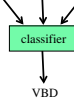

Slide from Ray Mooney

Sequence Labeling as Classification

- Classify each token independently but use as input features, information about the surrounding tokens (sliding window).

John saw the saw and decided to take it to the table.

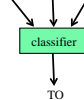

Slide from Ray Mooney

Sequence Labeling as Classification

- Classify each token independently but use as input features, information about the surrounding tokens (sliding window).

John saw the saw and decided to take it to the table.

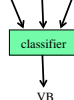

Slide from Ray Mooney

Sequence Labeling as Classification

- Classify each token independently but use as input features, information about the surrounding tokens (sliding window).

John saw the saw and decided to take it to the table.

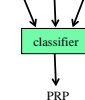

Slide from Ray Mooney

Sequence Labeling as Classification

- Classify each token independently but use as input features, information about the surrounding tokens (sliding window).

John saw the saw and decided to take it to the table.

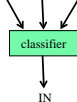

Slide from Ray Mooney

Sequence Labeling as Classification

- Classify each token independently but use as input features, information about the surrounding tokens (sliding window).

John saw the saw and decided to take it to the table.

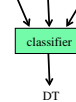

Slide from Ray Mooney

Sequence Labeling as Classification

- Classify each token independently but use as input features, information about the surrounding tokens (sliding window).

John saw the saw and decided to take it to the table.

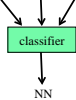

Slide from Ray Mooney

Part of Speech Tagging

- Or we could use an HMM:

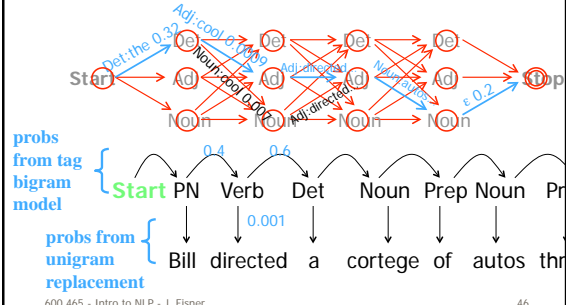

600.465 - Intro to NLP - J. Eisner

46

Part of Speech Tagging

- We could treat tagging as a token classification problem
 - Tag each word independently given features of context
 - And features of the word's spelling (suffixes, capitalization)
- Or we could use an HMM:
 - The point of the HMM is basically that the tag of one word might depend on the tags of adjacent words.
- Combine these two ideas??
 - We'd like rich features (e.g., in a log-linear model), but we'd also like our feature functions to depend on adjacent tags.
 - So, the problem is to predict **all** tags together.

600.465 - Intro to NLP - J. Eisner

47

Supervised Learning Methods

- Easy to build a "yes" or "no" predictor from supervised training data
 - Plenty of software packages to do the learning & prediction
 - Lots of people in NLP never go beyond this ☹
- Similarly, easy to build a system that chooses from a small finite set
 - Basically the same deal
 - But runtime goes up linearly with the size of the set, unless you're clever (HW3)
- Harder to predict the best string or tree (set is exponentially large or infinite)

Part of Speech Tagging

- Idea #1
 - Classify tags one at a time **from left to right**
- Each feature function can look at the context of the word being tagged, **including the tags of all previous words**

600.465 - Intro to NLP - J. Eisner

49

Forward Classification

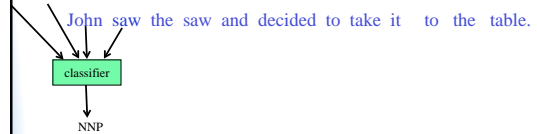

Slide from Ray Mooney

Forward Classification

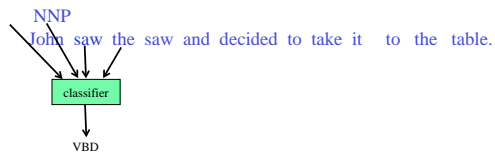

Slide from Ray Mooney

Forward Classification

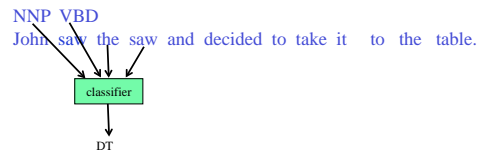

Slide from Ray Mooney

Forward Classification

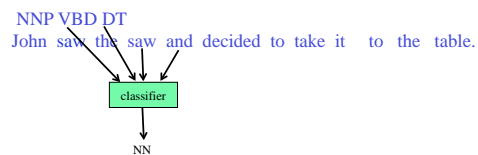

Slide from Ray Mooney

Forward Classification

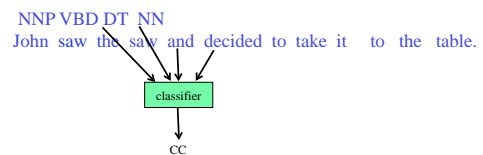

Slide from Ray Mooney

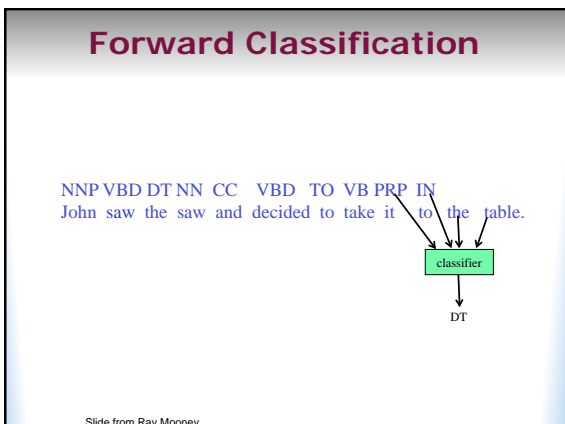
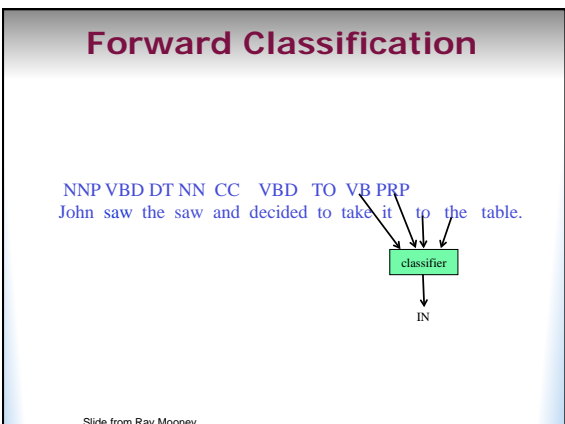
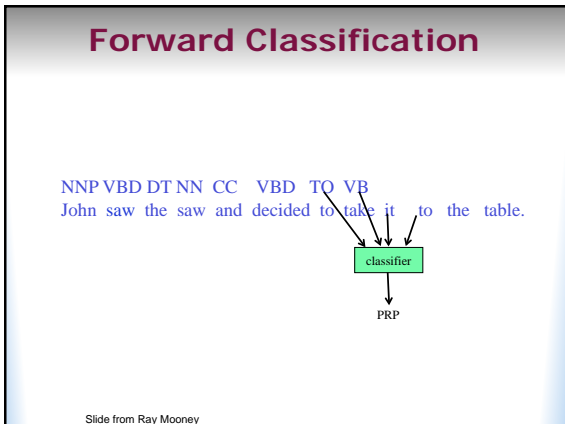
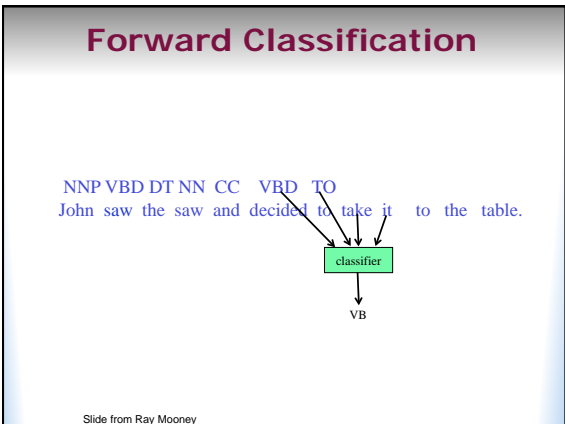
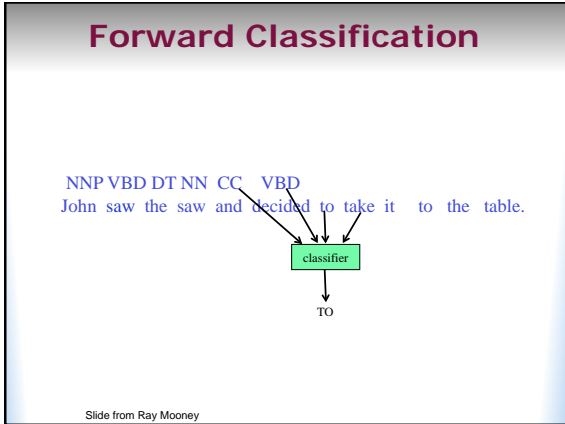
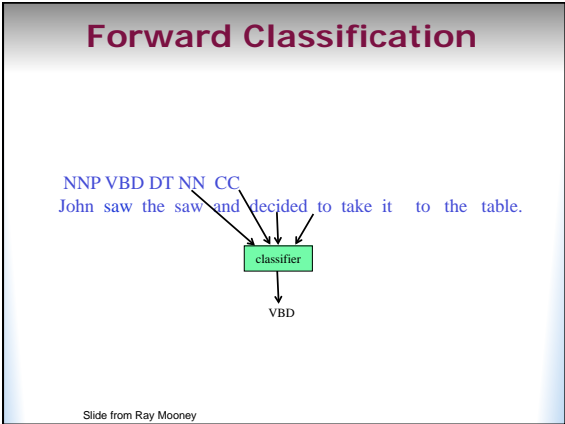

Forward Classification

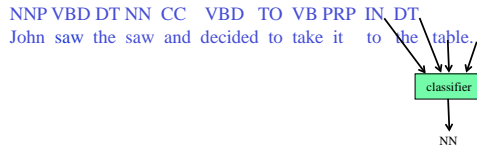

Slide from Ray Mooney

Backward Classification

- Disambiguating "to" in this case would be even easier backward.

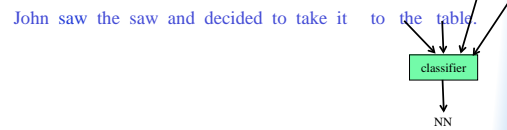

Slide from Ray Mooney

Backward Classification

- Disambiguating "to" in this case would be even easier backward.

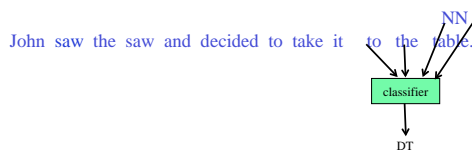

Slide from Ray Mooney

Backward Classification

- Disambiguating "to" in this case would be even easier backward.

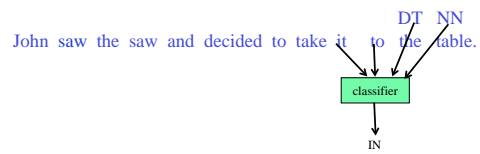

Slide from Ray Mooney

Backward Classification

- Disambiguating "to" in this case would be even easier backward.

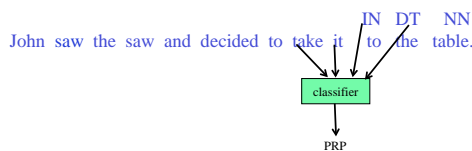

Slide from Ray Mooney

Backward Classification

- Disambiguating "to" in this case would be even easier backward.

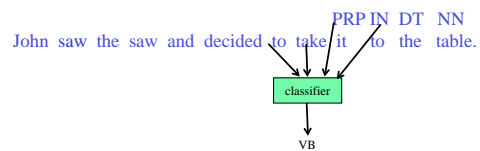

Slide from Ray Mooney

Backward Classification

- Disambiguating "to" in this case would be even easier backward.

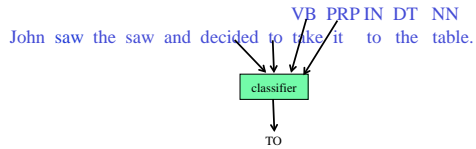

Slide from Ray Mooney

Backward Classification

- Disambiguating "to" in this case would be even easier backward.

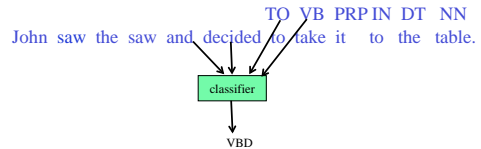

Slide from Ray Mooney

Backward Classification

- Disambiguating "to" in this case would be even easier backward.

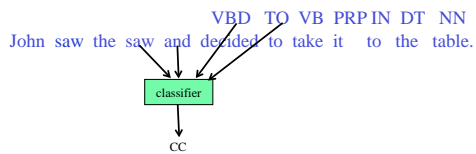

Slide from Ray Mooney

Backward Classification

- Disambiguating "to" in this case would be even easier backward.

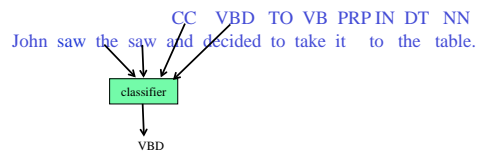

Slide from Ray Mooney

Backward Classification

- Disambiguating "to" in this case would be even easier backward.

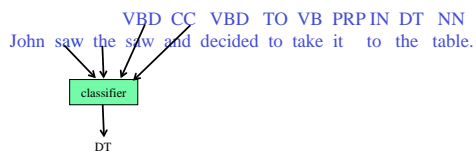

Slide from Ray Mooney

Backward Classification

- Disambiguating "to" in this case would be even easier backward.

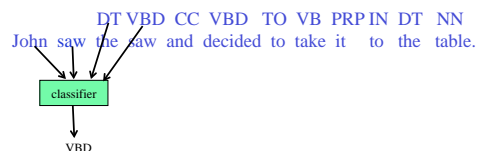

Slide from Ray Mooney

Backward Classification

- Disambiguating "to" in this case would be even easier backward.

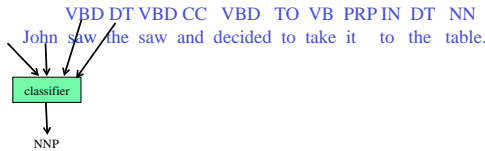

Slide from Ray Mooney

Part of Speech Tagging

- Idea #1**
 - Classify tags one at a time **from left to right**
 - $p(\text{tag} | \text{wordseq, prevtags}) = (1/Z) \exp \text{score}(\text{tag, wordseq, prevtags})$
 - where Z sums up $\exp \text{score}(\text{tag, wordseq, prevtags})$ over all possible tags
 - Each feature function can look at the context of the word being tagged, **including the tags of all previous words**
 - Asymmetric: can't look at following tags, only preceding ones
- Idea #2** ("maximum entropy Markov model (MEMM)")
 - Same model, but don't **commit** to a tag before we predict the next tag. Instead, consider probabilities of all tag **sequences**.

600.465 - Intro to NLP - J. Eisner

74

Maximum Entropy Markov Model

Is this a probable tag sequence for this sentence?

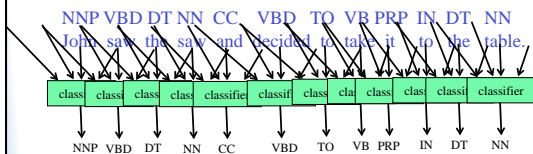

Does each of these classifiers assign a high probability to the desired tag?

Is this the most likely sequence to get by rolling dice?
(Does it maximize product of probabilities?)

Slide adapted from Ray Mooney

Part of Speech Tagging

- Idea #1**
 - Classify tags one at a time **from left to right**
 - $p(\text{tag} | \text{wordseq, prevtags}) = (1/Z) \exp \text{score}(\text{tag, wordseq, prevtags})$
 - where Z sums up $\exp \text{score}(\text{tag, wordseq, prevtags})$ over all possible tags
 - Each feature function can look at the context of the word being tagged, **including the tags of all previous words**
 - Asymmetric: can't look at following tags, only preceding ones
- Idea #2** ("maximum entropy Markov model (MEMM)")
 - Same model, but don't **commit** to a tag before we predict the next tag. Instead, consider probabilities of all tag **sequences**.
 - Use dynamic programming to find the most probable sequence
 - For dynamic programming to work, features can only consider the $(n-1)$ previous tags, just as in an HMM
 - Same algorithms as in an HMM, but now transition probability is $p(\text{tag} | \text{previous } n-1 \text{ tags and all words})$
 - Still asymmetric: can't look at following tags

600.465 - Intro to NLP - J. Eisner

76

Part of Speech Tagging

- Idea #1**
 - Classify tags one at a time **from left to right**
 - $p(\text{tag} | \text{wordseq, prevtags}) = (1/Z) \exp \text{score}(\text{tag, wordseq, prevtags})$
 - where Z sums up $\exp \text{score}(\text{tag, wordseq, prevtags})$ over all possible tags
- Idea #2** ("maximum entropy Markov model (MEMM)")
 - Same model, but don't **commit** to a tag before we predict the next tag. Instead, evaluate probability of every tag sequence.
- Idea #3** ("linear-chain conditional random field (CRF)")
 - This version is symmetric, and very popular.
 - Score each tag sequence as a whole, using arbitrary features
 - $p(\text{tagseq} | \text{wordseq}) = (1/Z) \exp \text{score}(\text{tagseq, wordseq})$
 - where Z sums up $\exp \text{score}(\text{tagseq, wordseq})$ over competing tagseqs
 - Can still compute Z and best path using dynamic programming
 - Dynamic programming works if, for example, each feature $f(\text{tagseq, wordseq})$ considers at most an n -gram of tags.
 - Then you can score a (tagseq, wordseq) pair with a WFST whose state remembers the previous $(n-1)$ tags.
 - As in #2, arc weight can consider the current tag n -gram **and all words**.
 - But unlike #2, arc weight isn't a probability (only normalize at the end).

600.465 - Intro to NLP - J. Eisner

77

Supervised Learning Methods

- Easy to build a "yes" or "no" predictor from supervised training data**
 - Plenty of software packages to do the learning & prediction
 - Lots of people in NLP never go beyond this ☺
- Similarly, easy to build a system that chooses from a small finite set**
 - Basically the same deal
 - But runtime goes up linearly with the size of the set, unless you're clever (HW3)
- Harder to predict the best string or tree (set is exponentially large or infinite)**
 - Requires dynamic programming: you might have to write your own code
 - But finite-state or CRF toolkits will find the best string for you
 - And you could modify someone else's parser to pick the best tree
 - An algorithm for picking the best can usually be turned into a learning algorithm

Text Annotation Tasks

1. Classify the entire document
2. Classify individual word tokens
3. Identify phrases ("chunking")

600.465 - Intro to NLP - J. Eisner

79

Named Entity Recognition

CHICAGO (AP) — Citing high fuel prices, **United Airlines** said Friday it has increased fares by \$6 per round trip on flights to some cities also served by lower-cost carriers. **American Airlines**, a unit **AMR**, immediately matched the move, spokesman **Tim Wagner** said. **United**, a unit of **UAL**, said the increase took effect Thursday night and applies to most routes where it competes against discount carriers, such as **Chicago** to **Dallas** and **Atlanta** and **Denver** to **San Francisco**, **Los Angeles** and **New York**.

12/12/11

Slide from Jim Martin

80

NE Types

Type	Tag	Sample Categories
People	PER	Individuals, fictional characters, small groups
Organization	ORG	Companies, agencies, political parties, religious groups, sports teams
Location	LOC	Physical extents, mountains, lakes, seas
Geo-Political Entity	GPE	Countries, states, provinces, counties
Facility	FAC	Bridges, buildings, airports
Vehicles	VEH	Planes, trains, and automobiles

Type	Example
People	<i>Turing</i> is often considered to be the father of modern computer science.
Organization	The <i>IPCC</i> said it is likely that future tropical cyclones will become more intense.
Location	The <i>Mt. Sanitas</i> loop hike begins at the base of <i>Sunshine Canyon</i> .
Geo-Political Entity	<i>Palo Alto</i> is looking at raising the fees for parking in the University Avenue district.
Facility	Drivers were advised to consider either the <i>Tappan Zee Bridge</i> or the <i>Lincoln Tunnel</i> .
Vehicles	The updated <i>Mini Cooper</i> retains its charm and agility.

Slide from Jim Martin

81

Information Extraction

As a task: **Filling slots in a database from sub-segments of text.**

October 14, 2002, 4:00 a.m. PT

For years, **Microsoft Corporation CEO Bill Gates** railed against the economic philosophy of open-source software with Orwellian fervor, denouncing its communal licensing as a "cancer" that stifled technological innovation.

Today, Microsoft claims to "love" the open-source concept, by which software code is made public to encourage improvement and development by outside programmers. Gates himself says Microsoft will gladly disclose its crown jewels—the coveted code behind the Windows operating system—to select customers.

"We can be open source. We love the concept of shared source," said **Bill Venghe**, a **Microsoft** VP. "That's a super-important shift for us in terms of code access."

Richard Stallman, founder of the **Free Software Foundation**, countered saying...



NAME	TITLE	ORGANIZATION
Bill Gates	CEO	Microsoft
Bill Venghe	VP	Microsoft
Richard Stallman	founder	Free soft...

Slide from Chris Brew, adapted from slide by William Cohen

Phrase Types to Identify for IE

Closed set

U.S. states

He was born in Alabama...

The big Wyoming sky...

Regular set

U.S. phone numbers

Phone: (413) 545-1323

The CALD main office can be reached at 412-268-1299

Complex pattern

U.S. postal addresses

University of Arkansas
P.O. Box 140
Hope, AR 71802

Headquarters:
1128 Main Street, 4th Floor
Cincinnati, Ohio 45210

Ambiguous patterns, needing context and many sources of evidence

Person names

...was among the six houses sold by Hope Feldman that year.

Pawel Opalinski, Software Engineer at WhizBang Labs.

Slide from Chris Brew, adapted from slide by William Cohen

Identifying phrases

- A key step in IE is to identify relevant phrases
 - Named entities
 - As on previous slides
 - Relationship phrases
 - "said", "according to", ...
 - "was born in", "hails from", ...
 - "bought", "hopes to acquire", "formed a joint agreement with", ...
 - Simple syntactic chunks (e.g., non-recursive NPs)
 - "Syntactic chunking" sometimes done before (or instead of) parsing
 - Also, "segmentation": divide Chinese text into words (no spaces)
- So, how do we learn to mark phrases?
 - Earlier, we built an FST to mark dates by inserting brackets
 - But, it's common to set this up as a tagging problem ...

Reduce to a tagging problem ...

- The IOB encoding (Ramshaw & Marcus 1995):
 - B_X = "beginning" (first word of an X)
 - I_X = "inside" (non-first word of an X)
 - O = "outside" (not in any phrase)
 - Does not allow overlapping or recursive phrases

... **United Airlines** said Friday it has increased ...

B_ORG I_ORG O O O O O

... the move , spokesman **Tim Wagner** said ...

O O O O B_PER I_PER O

What if this were tagged as B_ORG instead?

Slide adapted from Chris Brew

85

Some Simple NER Features

POS tags and chunks from earlier processing

Features	Label
American NNP B _{NP} cap	B_ORG
Airlines NNPS I _{NP} cap	I_ORG
. PUNC O punc	O
a DT B _{NP} lower	O
unit NN I _{NP} lower	O
of IN B _{PP} lower	O
AMR NNP B _{NP} upper	B_ORG
Corp. NNP I _{NP} cap_punc	I_ORG
. PUNC O punc	O
immediately RB B _{ADJP} lower	O
matched VBD B _{VP} lower	O
the DT B _{NP} lower	O
move NN I _{NP} lower	O
. PUNC O punc	O
spokesman NN B _{NP} lower	O
Tim NNP I _{NP} cap	B_PER
. PUNC O punc	O
. PUNC O punc	O

Now predict NER tagseq

A feature of this tagseq might give a positive or negative weight to this B_ORG in conjunction with some subset of the nearby properties

Or even faraway properties: B_ORG is more likely in a sentence with a spokesman!

Slide adapted from Jim Martin

86

Example applications for IE

- Classified ads
- Restaurant reviews
- Bibliographic citations
- Appointment emails
- Legal opinions
- Papers describing clinical medical studies

Text Annotation Tasks

- Classify the entire document
- Classify individual word tokens
- Identify phrases ("chunking")
- Syntactic annotation (parsing)

600.465 - Intro to NLP - J. Eisner

88

Parser Evaluation Metrics

- Runtime
- Exact match
 - Is the parse 100% correct?
- Labeled precision, recall, F-measure of constituents
 - Precision: You predicted (NP,5,8): was it right?
 - Recall: (NP,5,8) was right: did you predict it?
- Easier versions:
 - Unlabeled: Don't worry about getting (NP,5,8) right, only (5,8)
 - Short sentences: Only test on sentences of ≤ 15 , ≤ 40 , ≤ 100 words
 - Dependency parsing: Labeled and unlabeled attachment accuracy
- Crossing brackets
 - You predicted (...5,8), but there was really a constituent (...6,10)

Labeled Dependency Parsing

Raw sentence

He reckons the current account deficit will narrow to only 1.8 billion in September.

Part-of-speech tagging

POS-tagged sentence

PRP VBZ DT JJ NN NN MD VB TO RB CD CD IN NNP .

Word dependency parsing

Word dependency parsed sentence

He reckons the current account deficit will narrow to only 1.8 billion in September .

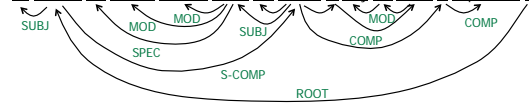

slide adapted from Yuji Matsumoto

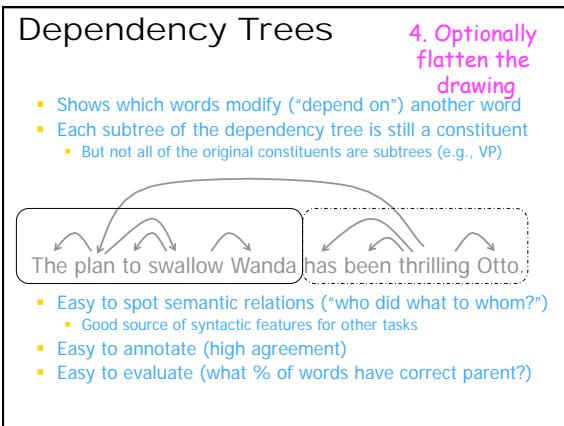
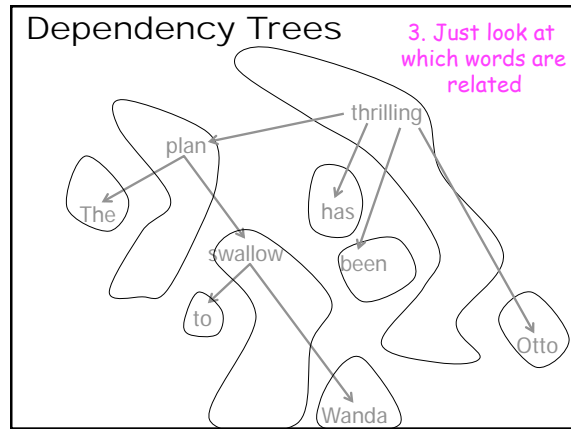
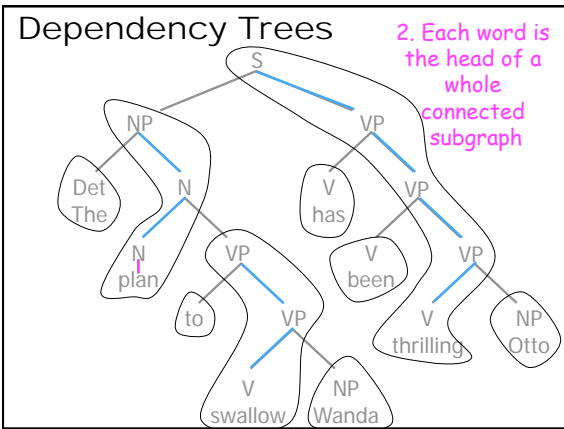
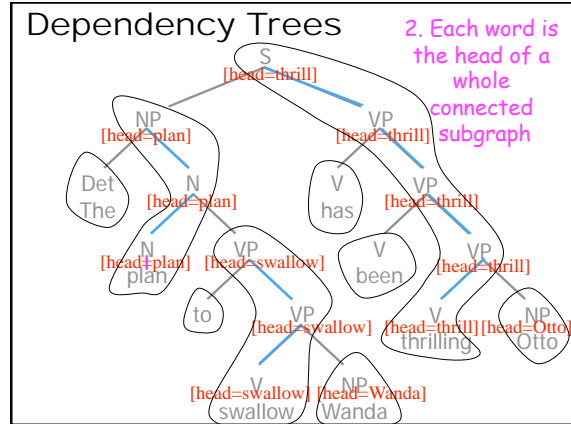
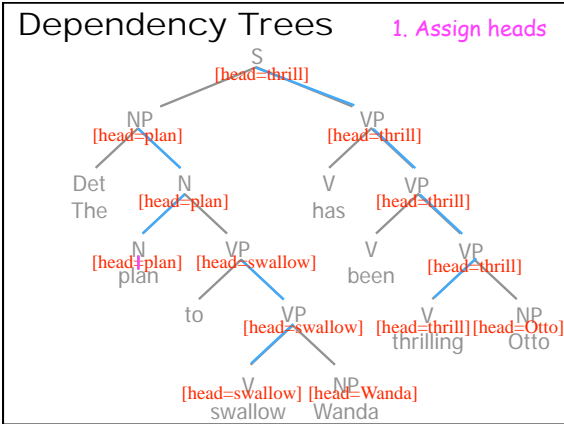

- ### Supervised Learning Methods
- Easy to build a "yes" or "no" predictor from supervised training data
 - Plenty of software packages to do the learning & prediction
 - Lots of people in NLP never go beyond this ☺
 - Similarly, easy to build a system that chooses from a small finite set
 - Basically the same deal
 - But runtime goes up linearly with the size of the set, unless you're clever (HW3)
 - Harder to predict the best string or tree (set is exponentially large or infinite)
 - Requires dynamic programming; you might have to write your own code
 - But finite-state or CRF toolkits will find the best string for you
 - And you could modify someone else's parser to pick the best tree
 - An algorithm for picking the best can usually be turned into a learning algorithm
 - Hardest if your features look at "non-local" properties of the string or tree
 - Now dynamic programming won't work (or will be something awful like $O(n^2)$)
 - You need some kind of approximate search
 - Can be harder to turn approximate search into a learning algorithm
 - Still, this is a standard preoccupation of machine learning ("structured prediction," "graphical models")

Text Annotation Tasks

1. Classify the entire document
2. Classify individual word tokens
3. Identify phrases ("chunking")
4. Syntactic annotation (parsing)
5. Semantic annotation

6.00.465 - Intro to NLP - J. Eisner

97

Semantic Role Labeling (SRL)

- For each predicate (e.g., verb)
 1. find its arguments (e.g., NPs)
 2. determine their **semantic roles**

John drove Mary from Austin to Dallas in his Toyota Prius.

The hammer broke the window.

- **agent**: Actor of an action
- **patient**: Entity affected by the action
- **source**: Origin of the affected entity
- **destination**: Destination of the affected entity
- **instrument**: Tool used in performing action.
- **beneficiary**: Entity for whom action is performed

Slide thanks to Ray Mooney (modified) ⁹⁸

As usual, can solve as classification ...

- Consider one verb at a time: "bit"
- Classify the role (if any) of each of the 3 NPs

Color Code:

- not-a-role
- agent
- patient
- source
- destination
- instrument
- beneficiary

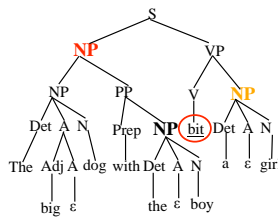

Slide thanks to Ray Mooney (modified) ⁹⁹

Parse tree paths as classification features

Path feature is

$V \uparrow VP \uparrow S \downarrow NP$

which tends to be associated with agent role

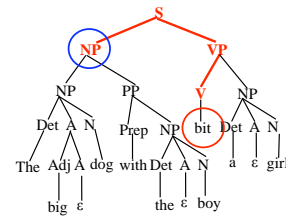

Slide thanks to Ray Mooney (modified) ¹⁰⁰

Parse tree paths as classification features

Path feature is

$V \uparrow VP \uparrow S \downarrow NP \downarrow PP \downarrow NP$

which tends to be associated with no role

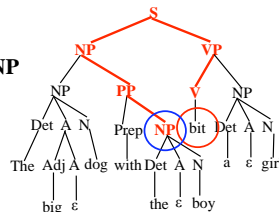

Slide thanks to Ray Mooney (modified) ¹⁰¹

Head words as features

- Some roles prefer to be filled by certain kinds of NPs.
- This can give us useful features for classifying accurately:
 - "John ate the spaghetti with chopsticks." (instrument)
 - "John ate the spaghetti with meatballs." (patient)
 - "John ate the spaghetti with Mary."
 - Instruments should be tools
 - Patient of "eat" should be edible
 - "John bought the car for \$21K." (instrument)
 - "John bought the car for Mary." (beneficiary)
 - Instrument of "buy" should be Money
 - Beneficiaries should be animate (things with desires)
 - "John drove Mary to school in the van"
 - "John drove the van to work with Mary."
 - What do you think?

Slide thanks to Ray Mooney (modified) ¹⁰²

Uses of Semantic Roles

- Find the answer to a user's question
 - "Who" questions usually want Agents
 - "What" question usually want Patients
 - "How" and "with what" questions usually want Instruments
 - "Where" questions frequently want Sources/Destinations.
 - "For whom" questions usually want Beneficiaries
 - "To whom" questions usually want Destinations
- Generate text
 - Many languages have specific syntactic constructions that must or should be used for specific semantic roles.
- Word sense disambiguation, using selectional restrictions
 - The **bat** ate the **bug**. (what kind of bat? what kind of bug?)
 - Agents (particularly of "eat") should be animate – animal bat, not baseball bat
 - Patients of "eat" should be edible – animal bug, not software bug
 - John **fi**red the secretary.
 - John **fi**red the rifle.
 - Patients of fire, are different than patients of fire,

108
Slide thanks to Ray Mooney (modified)

Other Current Semantic Annotation Tasks (similar to SRL)

- PropBank – coarse-grained roles of verbs
- NomBank – similar, but for nouns
- FrameNet – fine-grained roles of any word
- TimeBank – temporal expressions

FrameNet Example

REVENGE FRAME

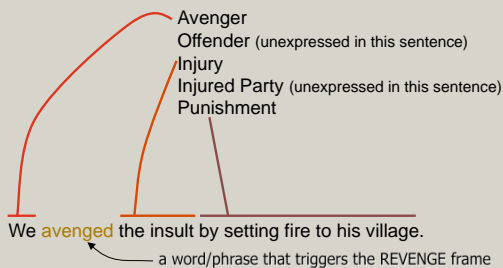

Slide thanks to CJ Fillmore (modified)

FrameNet Example

REVENGE FRAME triggering words and phrases (not limited to verbs)

avenge, revenge, retaliate, get back at, pay back, get even, ...
revenge, vengeance, retaliation, retribution, reprisal, ...
vengeful, retaliatory, retributive; in revenge, in retaliation, ...
take revenge, wreak vengeance, exact retribution, ...

Slide thanks to CJ Fillmore (modified)

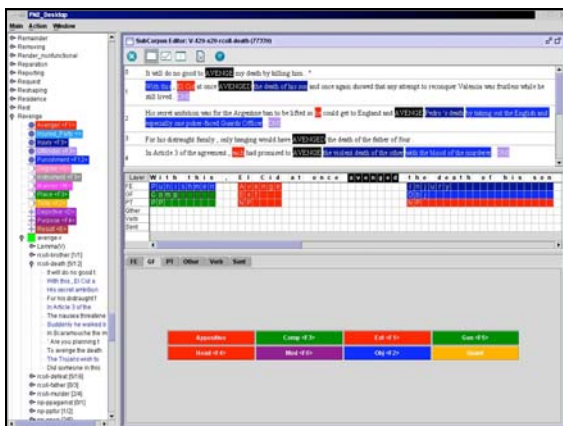

Generating new text

- Speech recognition (transcribe as text)
- Machine translation
- Text generation from semantics
- Inflect, analyze, or transliterate words
- Single- or multi-doc summarization

600.465 - Intro to NLP - J. Eisner

108

Deeper Information Extraction

1. Entity linking
2. Knowledge base population (KBP)
3. Event extraction
4. Recognizing textual entailment (RTE)

600.465 - Intro to NLP - J. Eisner

109

User interfaces

1. Dialogue systems
 - Personal assistance
 - Human-computer collaboration
 - Interactive teaching
2. Language teaching; writing help
3. Question answering
4. Information retrieval

600.465 - Intro to NLP - J. Eisner

110

Multimodal interfaces or modeling

1. Sign languages
2. Speech + gestures
3. Images + captions
4. Brain recordings, human reaction times

600.465 - Intro to NLP - J. Eisner

111

Structure Learning

1. Decipherment
2. Grammar induction
3. Topic modeling
4. Deep learning of word meanings
5. Language evolution (historical linguistics)
6. Grounded semantics

600.465 - Intro to NLP - J. Eisner

112